

Drawing for Graphic Communications

number Art 3334

Project 4: Iconic Representation



Banksy, London



Anonymous, Granada, Spain



Beijing 2008 Olympics, by AICA

Personal Mark/Symbol

Make your own personal mark/symbol that can be translated into a stencil (hard-edge form). Your mark may be abstract or symbolic. It may be based on your initials, name or an image/icon of personal significance. Ask yourself what your mark stands for (other than yourself). What text (word or words) would you put next to your mark.

Popular Culture Collection

Collect a range of ephemera based on popular culture that is interesting to you, such as: photographs of people, places, or objects; current events or issues from magazines or newspapers; lyrics; ticket-stubs; business cards; fast-food debris; labels and packaging; etc. Bring collections of popular culture to class

Inspiration

Look at work by artist Basquiat, designer Ryan McGuinness, graffiti or other art and design sources. Bring visual research that inspires you to class.

Process

Begin by developing your personal symbol stencil. For the first critique, bring a minimum of 6 felt-tip renderings of mark on tracing paper. On the same or separate paper present copies of images, symbols, etc. from your personal collection that inspired your mark. Refine the best mark and cut into stencil format.

Layered Residue

Make three large scale drawings/collages (12 x 12 inches) based on popular culture collection. Each drawing or collage should have your personal mark as well as other elements such as; other mark-making, writing/text, drawing, transfers, photocopies, other collage material.

Objective

- Passion and expression
- Merging the processes examined during the semester to create a series of works: drawing, color, texture, media, composition.
- Do not make a mess! Control your media, create dynamic negative space, contrast

Final Format 1: Big Series

- Select one 12 x 12 inch mixed surface drawing/collage from the series of three that you will develop for class crits. Flush mount this one on 12 x 12 inch foam-board (no border!!)
- One 6 x 6 inch accordion fold book or bound book containing 6 panels. Three of these will be reductions of your large collages. Design three more 6 x 6 collages for book.

Media

Mixed media with a variety of paper use.

Sketchbook

No sketchbook

Schedule

November

M 5 | T 6 Discuss personal collections + work in class on mark/symbols

W 8 | TH 9 Review personal collections + inspiration sources + crit 6 mark/symbol sketches

M 12 | T 13 Crit 3 personal symbol refinements and stencils + work in class.

W 14 | TH 15 Work on large scale drawings/collages

M 19 | T 20 Crit 3 large scale drawing/collages + work in class. Crit accordion book mock up.

W 21 Crit revised collages + work in class

TH 22 Thanksgiving / No class

M 26 | T 27 Crit six 6 x 6 panels for book

W 28 | TH 29 Last day. Final portfolio due. Turn in all projects and sketchbooks from semester. Submit reworked projects for revised grades.

December

F 7 Pick up graded portfolios.

Portfolios may be picked up between 8:30 am and 4:30 pm beginning Friday, Dec. 7 through Friday, Dec. 14. After Dec. 14 the university will be closed for winter break and portfolios may be discarded as trash. If portfolios survive the end of semester clean up, you may look for yours in spring 2008.

Drawing for Graphic Communications number Art 3334

Accordion Book with LetraMax

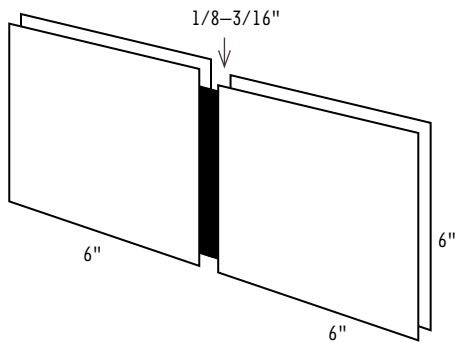
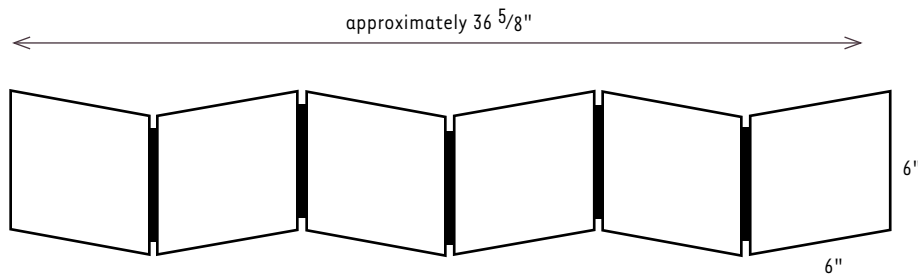

Method 1

Sandwich a strip of black tape or cloth that is approximately 1 x 5 inches between two 6 x 6 inch pieces of black LetraMax. Leave a 1/8 to 3/16 inch gap between adjoining panels.

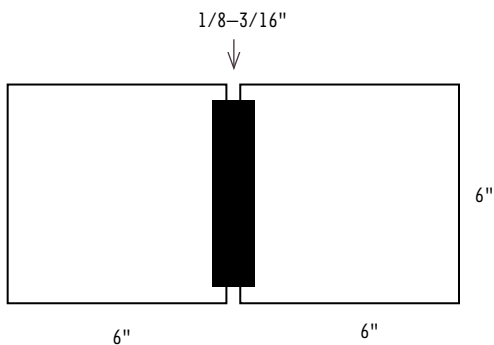

Method 2

Join two 6 x 6 inch pieces of black LetraMax by taping them together on their backsides with black tape. Consider using black linen tape, which can sometimes be found with book-making supplies in art stores. Leave a 1/8 to 3/16 inch gap between adjoining panels.